

RADA



**A-PC01
PanoCam**

USER MANUAL

www.a-dena.com

Adena Limited 2024

This manual provides information relevant to the installation of the A-PC01 PanoCam, as well as its functions and control methods in detail. Please read this manual carefully before installing and using the camera.

- A-PC01 PanoCam comes with its own power adapter. Power should not be extended from its jack, otherwise it may cause damage to the device. Please avoid using third-party power adapters to avoid incompatibility and consequent damage to the equipment. Note that the A-PC01 PanoCam also supports PoE (802.3 af), meaning that you do not need to connect the power adapter if you have a PoE switch/injector.
- You should only store and transport the camera in its operating temperature range, which is between 0° and 40°. The ambient humidity range is from 10%RH to 90%RH.
- Avoid excessive shaking or applying force to the camera.
- To avoid electric shock, do not remove screws or housing from the camera. You should not attempt to repair the camera yourself. In case of technical issues, reach out to www.a-dena.com for support.
- Use soft cloth to clean the camera. If it is very dirty, wet the cloth in a weak solution of water and neutral kitchen detergent. Wring all liquid from the cloth, then wipe the camera with it gently. Clear the remaining dirt with another dry, soft cloth. Use lens cleaning paper for the lens.

Table of Contents

1. Product Overview	3
1.1 Physical Interface Description and Diagrams	3
1.2 Bracket Installation	4
1.3 How to Quickly Start Up the Camera	5
2. Web Interface Description	6
2.1 Pages and Functions	6
2.1.1 Live View / OSD Menu Description	7
2.1.2 Audio Config	14
2.1.3 Video Config / How to Add the Camera's RTSP Streams	14
2.1.4 Media Config / How to Set Up RTMP Streaming	16
2.1.5 Control Protocol Config / How to Set Up VISCA-over-IP	17
2.1.6 System Config	19
2.1.7 Device Info	20

1. Product Overview

1.1 Physical Interface Description and Diagrams

Front and Back Views of the Camera:

Front View

Side View

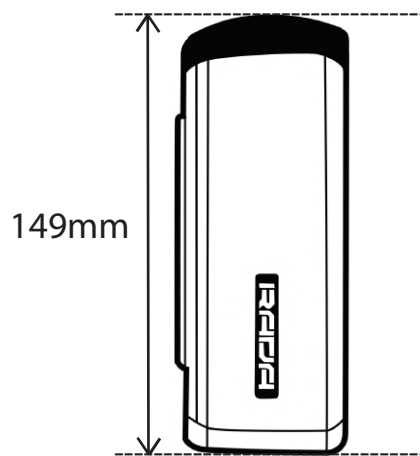
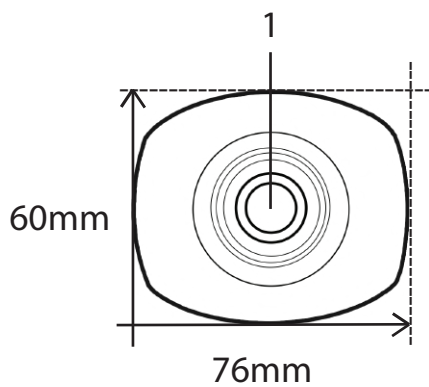

Back View

Bottom View

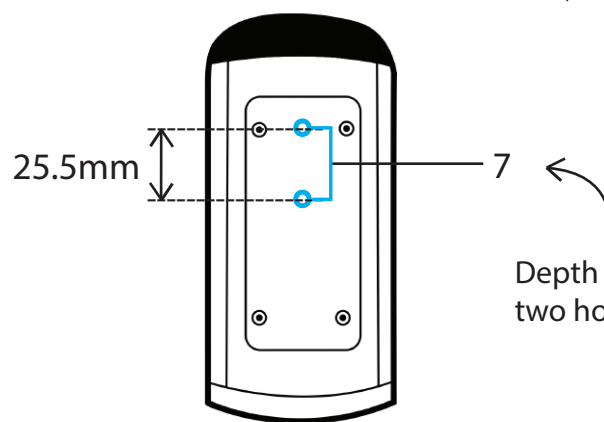
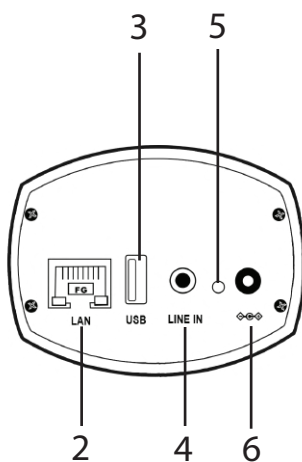

1. Camera lens.
2. Network port (supports PoE).
3. USB 2.0 Type-A.
4. Line input.
5. Power LED indicator.
6. Power input (DC12V).
7. Mounting holes
(for 1/4" screws, 20 UNC thread).

Depth to bottom surface is 6mm,
two holes for 1/4" screws, 20 UNC.

1.2 Bracket Installation

The bracket that comes with PanoCam is primarily designed to mount the camera on walls. Ceiling installation is possible, but the camera will have to be mounted at an angle. If you need the camera to be straight when mounted on a ceiling, we recommend using the RADA A-B02 bracket instead.

Before installing the bracket, please make sure that there is enough space for the camera and its cables. Check that the surface is safe enough to hold the camera and its components. For safety, we recommend installing the bracket only on surfaces that can hold at least 4 times the weight of the camera and its parts.

Drill 4 holes in the installation surface matching the dimensions of the bracket as shown on the image below.

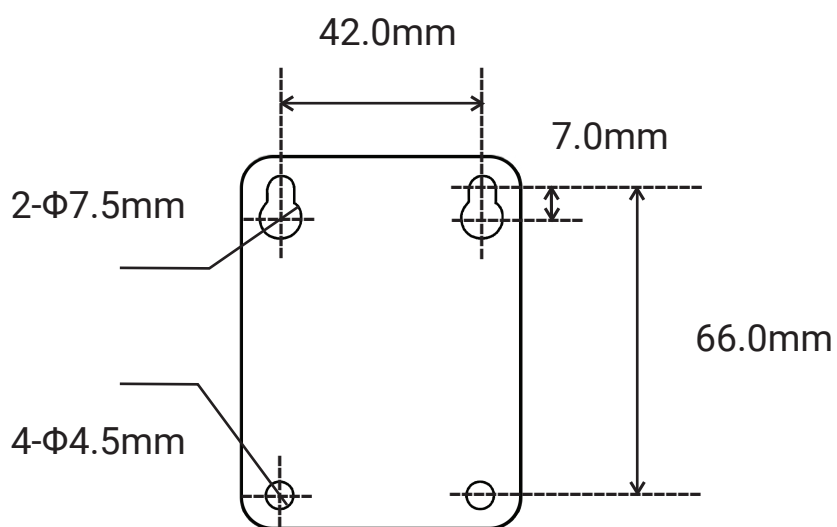

Fix the camera on the bracket with screws and adjust the limiting screw to lock the camera in your desired position. Make sure that the camera is fixed tightly before you let go of it.

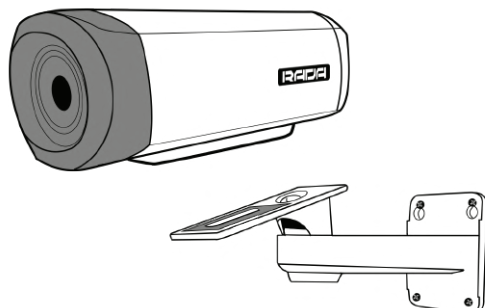

1.3 How to Quickly Start Up the Camera

The A-PC01 PanoCam can be used out of the box. To use it as a USB camera, simply connect it via any USB Type-A cable to your device. It will be recognised as the “RADA PanoCam”. You can then adjust its video parameters through your software or hardware.

To open or use its RTSP network stream, open any network player, such as VLC, and enter either of the camera’s RTSP addresses:

Main stream: `rtsp://camera’s IP address/ch1`

Substream: `rtsp://camera’s IP address/ch2`

The default IP address of the camera is 192.168.11.200. You can change it in the camera’s web interface.

You can also access the camera’s preview and ePTZ control through the ONVIF Device Manager or other ONVIF-compatible solutions, such as AREC Media Stations. When using ONVIF, the camera’s username and password are as follows:

Username: admin

Password: 123456

For more in-depth customisation, you can access the camera's web interface. By default, its IP address is 192.168.11.200. PanoCam's web interface username and password are as follows:

Username: admin

Password: admin123

If you do not know how to change the IP address of your computer to access the camera, please refer to the video [Nº26 How to Change the IP Address of your AREC Device](#) available on ADENA Limited YouTube channel, <https://www.youtube.com/@ADENACHannel>. The video describes how to put your computer into the same subnet as the camera, but keep in mind that you will need to set your PC to 192.168.11. to connect to the camera.

2. Web Interface Description

2.1 Page and Functions

Once you enter the IP address of your PanoCam, its web interface will open. Enter the default username and password to access the settings. These are:

Username: admin

Password: admin123

You can also tick a box to remain signed in on this computer for 7 days. Please note that should you change the IP address on either the PC or the camera during this time, you will need to log in again.

There are 7 subpages within the web interface of PanoCam:

- **Live View:** lists settings and controls related to the lens and ePTZ, and it is also the page where you can see the live preview and access the camera's OSD menu.
- **Audio Config:** lists settings related to the line input..

- **Video Config:** lists settings related to the camera's network streams' encoding.
- **Media Config:** controls the RTSP port number and the RTMP streaming from the camera.
- **Control Protocol Config:** lists VISCA control settings.
- **System Config:** controls the camera's usernames, passwords, and network settings. This is also where you can update the camera's firmware, reboot it, as well as reset it to factory settings.
- **Device Info:** shows the camera's model, current firmware version and MAC address.

2.1.1 Live View / OSD Menu Description

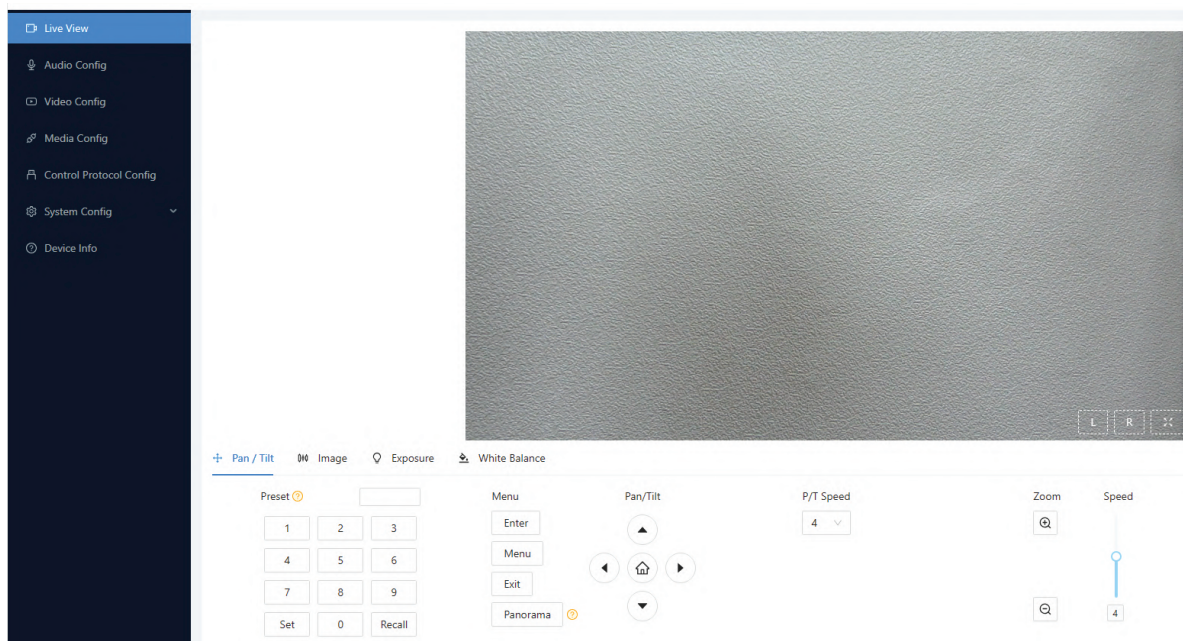

In the Pan / Tilt section of “Live View”, you can control the camera’s ePTZ functions. ePTZ cameras must first be zoomed in before you are able to use the directional arrows. You can zoom in and out using the “+” and “-” buttons on the right side of this page.

PanoCam supports up to 255 presets. To set a preset, move the camera in your desired position, write a number from 0 to 255 in the preset field, and press “Set”. To call this preset, enter its number in the preset field and press “Recall”.

Please note that the preset 0 is considered the “home” position of PanoCam. Adjust this preset if you would like to change where the camera is looking after rebooting or when clicking the home button.

In the camera preview on the Live view page, you are able to flip and tilt the camera image. Please note that this does not affect the video output of the camera. If you would like to change the image orientation, you can do so in the image settings.

The Pan / Tilt section also includes the OSD menu of PanoCam. To enter it, click “Menu”. An interface like this will open in the camera’s preview:

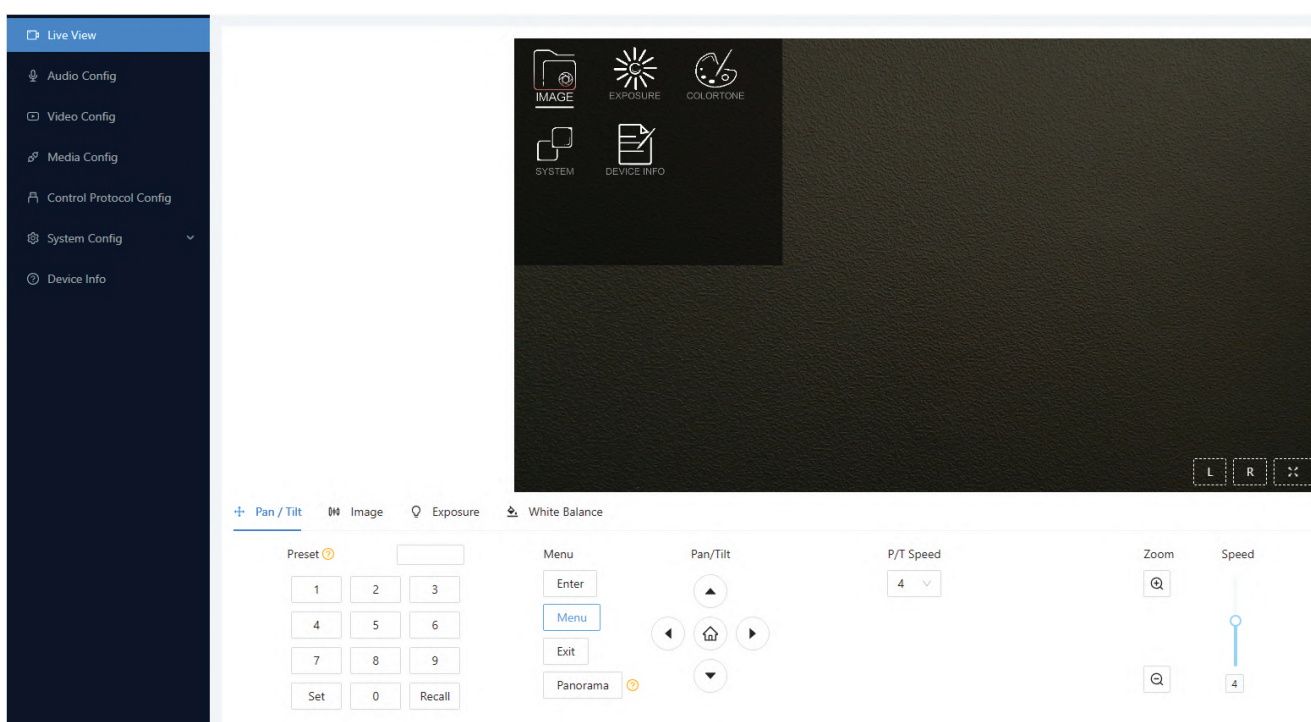

By default, the OSD menu is set to English. If the interface appears in another language, press the “Menu” button once, then arrow down, then “Enter”, then arrow down again, and then arrow left or right.

(1)

(2)

(3)

(4)

(5)

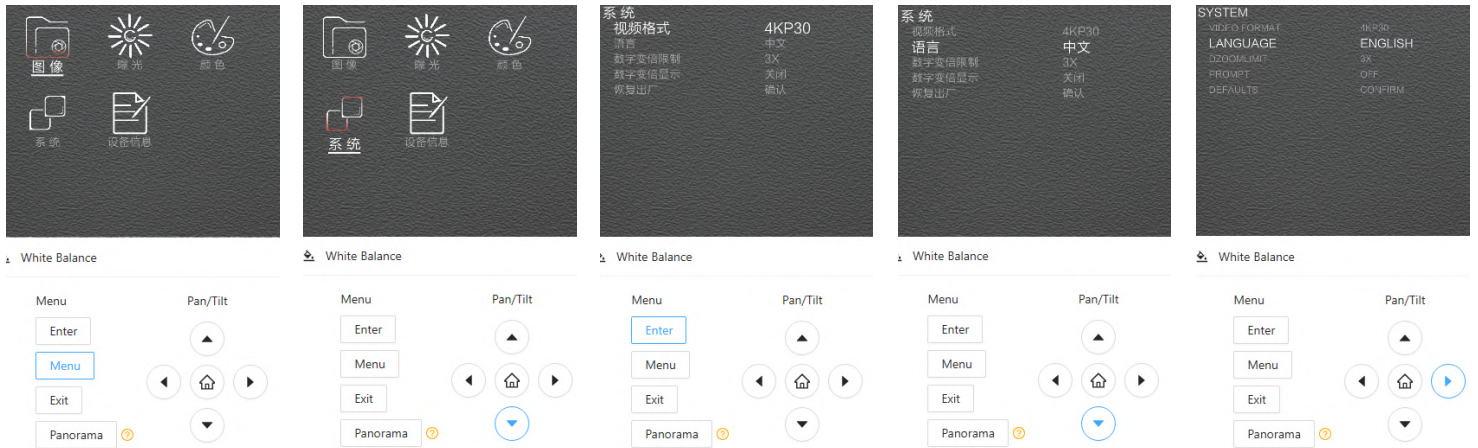

The OSD menu can be used to configure various lens parameters of the camera. You can also use it to adjust the maximum framerate of the camera. To do that, click on “Menu” -> “System” -> “Video Format” and use left or right arrows to change the mode. Press “Enter” to confirm changes. This will cause the camera to reboot.

The complete menu tree is described below:

Menu Configuration

<IMAGE>	SHARPNESS	0, 1, 2, 3, 4, 5, 6, 7, 8, 9, 10, 11
	BRIGHTNESS	0, 1, 2, 3, 4, 5, 6, 7, 8, 9, 10, 11, 12, 13, 14
	CONTRAST	0, 1, 2, 3, 4, 5, 6, 7, 8, 9, 10, 11, 12, 13, 14
	GAMMA	0, 1, 2, 3, 4
	2DNR	0, 1, 2, 3, 4, 5, 6, 7
	3DNR	0, 1, 2, 3, 4, 5, 6, 7
	DRC	0, 1, 2, 3, 4, 5
	MIRROR	ON, OFF
	FLIP	ON, OFF

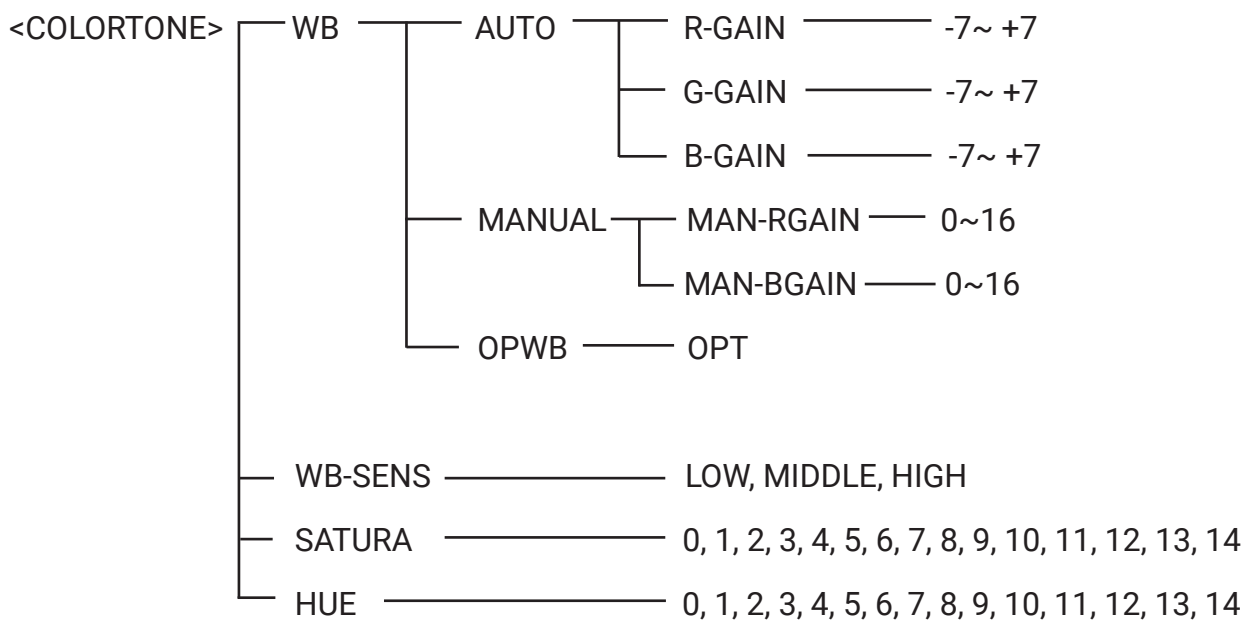
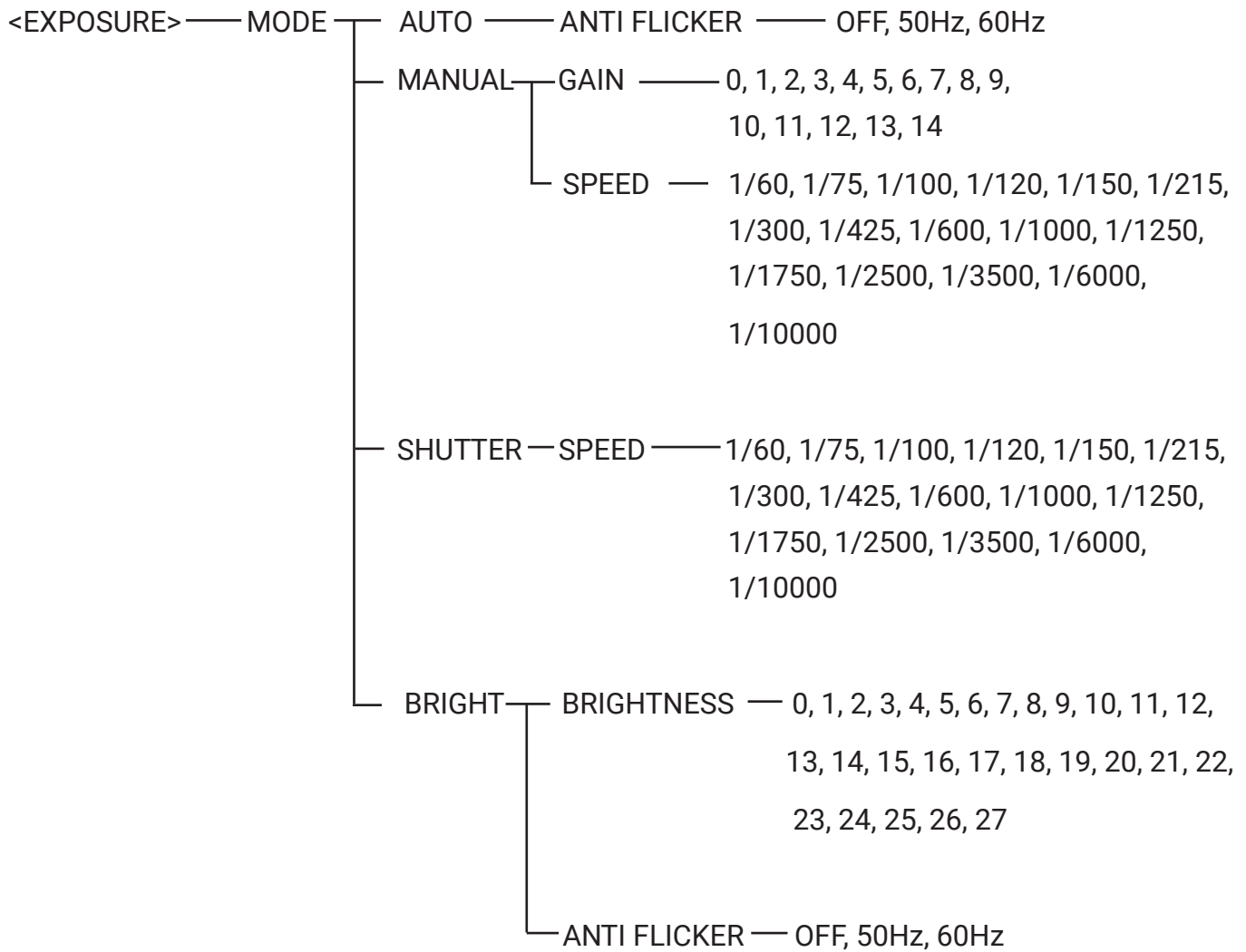

<SYSTEM>	VIDEO FORMAT	4KP30, 4KP25
	LANGUAGE	CHINESE, ENGLISH
	DZOOMLIMIT	2X, 3X, 4X, 5X, 6X, 7X, 8X
	DEFAULTS	CONFIRM

<DEVICE INFO> ——— FIRM VERSION

The camera's image settings can also be accessed through other sections on the Live View page: "Image", "Exposure", "White Balance".

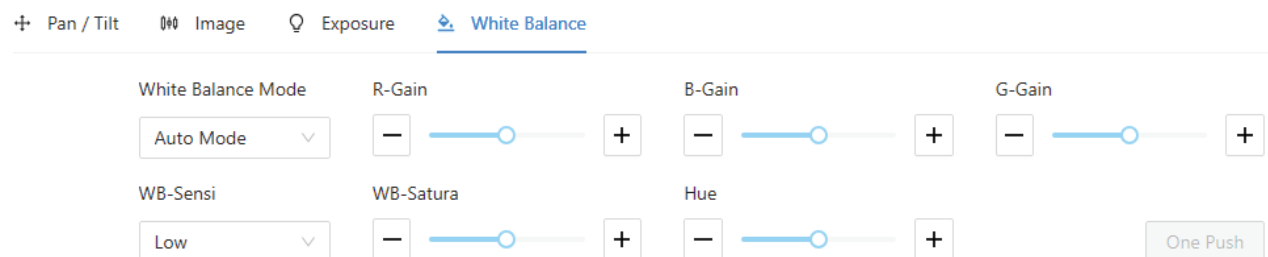
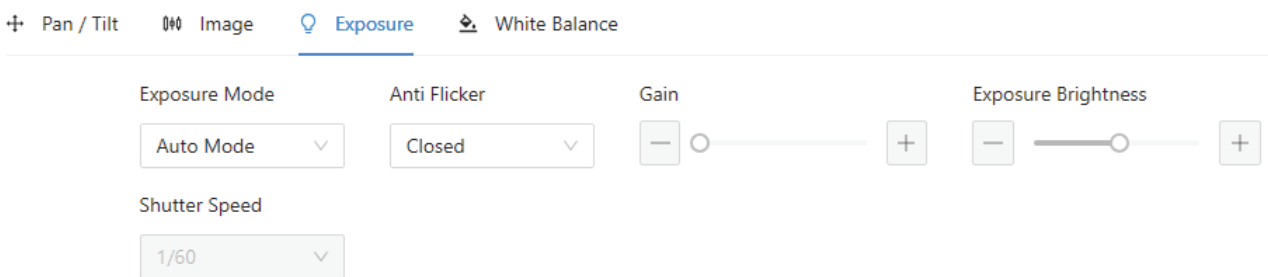
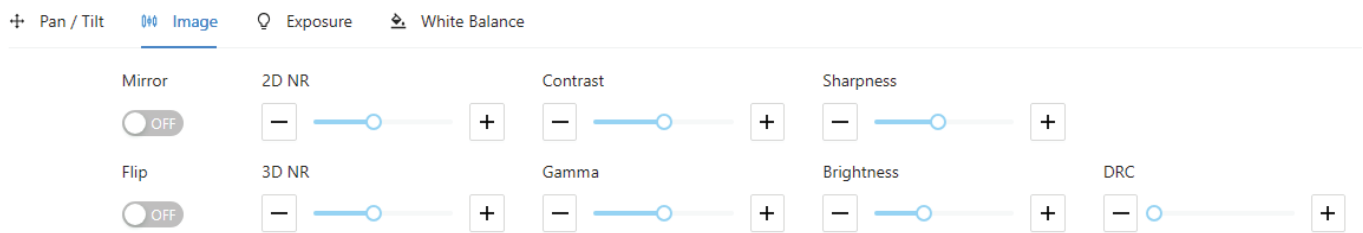

You can customise PanoCam's image in different ways using the Live View page and the OSD menu. Here is the description of each feature for your reference.

Menu	Options/Function	Description
Image	Sharpness	Sharpness controls the clarity and contrast of the edges in images. Increasing the value will make it easier to distinguish objects and shapes, but the image may appear pixelated at higher values.
	Brightness	Controls how bright or dark the image appears.
	Contrast	Controls the ratio between the brightest and the darkest areas of the image. Higher value increases the range of colours, making them richer and livelier.
	Gamma	Adjusts the image to match the perception of human eyes, making the image brighter. Setting it low makes darker objects harder to distinguish. Setting it higher makes everything brighter. Use the gamma slider to tune the image when shooting reflective surfaces and their surroundings.
	2DNR (Dynamic Noise Reduction)	Removes noise from images by comparing frames. Setting it higher will increase the intensity of this process. 2D DNR is most effective at resolutions below 1080p and on static images. Capturing moving images with 2D DNR enabled can cause blurriness.
	3DNR (Dynamic Noise Reduction)	Removes noise from single frames and compares frames to adjust for motion. Setting the value higher improves image quality and reduces jitter.
	DRC (Dynamic Range Compression)	Controls the gap between the brightest and the darkest areas. Increasing the value reduces the gap between these opposites, making the overall tonal and brightness levels more even. It will help bring out the details in the darker parts of the image, but will flatten it and lower contrast.
	Mirror	Turning on will rotate the camera image 180° horizontally.
Flip	Turning on will rotate the camera image 180° vertically.	
	Exposure Mode - Auto Mode	Automatically adjusts every parameter controlling how much light reaches the camera's sensor according to the environment.

Exposure	Anti Flicker	<p>Use this to remove the flickering effect from artificial light sources. Choose between:</p> <p>“Closed” - anti flicker is not engaged</p> <p>“50 Hz” - if the light sources are also using this frequency, the flickering effect will disappear.</p> <p>“60 Hz” if the light sources are also using this frequency, the flickering effect will disappear.</p> <p>You can also use different shutter speeds in Manual Exposure mode to combat flickering if these settings do not help.</p>
	Manual Exposure	<p>Select to manually control the shutter speed and gain. Shutter speed determines how fast the camera shutter closes. Higher speed lets in less light.</p> <p>Gain controls the amplification of the signal coming from the camera's sensor, making it more sensitive to light. Set higher to make the image brighter.</p>
	Shutter Priority	In this mode, the exposure slider is fixed, and the picture brightness is adjusted by the shutter speed.
	Brightness Priority	In this mode, the shutter is fixed, and the brightness is adjusted by the gain and exposure sliders.
Colortone	White Balance Mode - Auto Mode	Automatically controls how colours are captured by the camera, making them look natural and accurate, regardless of the lighting conditions.
	WB-Sensi (Sensitivity)	Controls how responsive the camera is to changes in the colour temperature of the light in the environment. The higher the value, the faster the camera will adjust to changes. Higher values may make the image look overly processed because of constant adjustment.
	White Balance Mode - Manual Mode	Select this to manually adjust the colour temperature, saturation and hue of your image.
	Saturation	Controls the purity and intensity of colours. Increasing saturation makes colours appear more vivid and vibrant, decreasing makes colours appear more muted, grayscale.
	Hue	Controls the overall colour of the image.
	White Balance Mode - One Press WB	Select this mode to adjust the colour temperature automatically according to a reference point. Point the camera at a neutral-coloured object (ideally, white) and click “One Push” to make it work.

2.1.2 Audio Config

In the Audio Config page, you are able to customise the level of the 3.5mm device you are connecting to the camera (Line or Mic), its sample rate and audio volume. Higher sample rate produces better audio quality, but may not be accepted by other devices.

All AREC Media Stations support 44.1 and 48 KHz input frequencies, and thus if you are using PanoCam as an audio source on our devices, you can select the highest frequency rate.

2.1.3 Video Config / How to Add the Camera's RTSP Streams

You can customise the network output streams of PanoCam on the Video Config page. Select which stream to customise under "Stream Type" and adjust its parameters as needed.

By default, PanoCam uses these links for its streams:

Main Stream: `rtsp://IP address of the camera/ch1`

Substream: `rtsp://IP address of the camera/ch2`

Default RTSP port: 554

Note that in the PanoCam's design, its two network streams serve different purposes and complement each other. The camera's main stream is limited to Full HD and ePTZ is enabled on it. The camera's substream supports 4K, but cannot be controlled by the ePTZ. The main stream is cutting out an image fragment from the substream and allows users to navigate it with ePTZ. Therefore, selecting 4K in the substream directly improves the image quality of the main stream, as the camera will be able to cut out Full HD resolution without lowering the amount of pixels in a particular fragment.

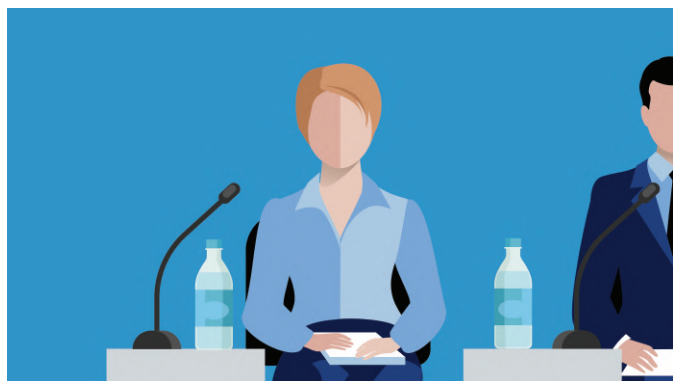

Main Stream (Full HD)



Substream (4K)

Please be aware that the framerate of the camera's streams is determined by two options. It is directly controlled by the "Video Frame Rate" parameter found in the Video Config page, but it is also controlled by the "Video Format" setting found in the camera's OSD Menu -> "System". If the camera is set to 4KP25 in the "Video Format", the maximum available resolution will be 25 frames, even if "Full frame rate" is selected on the Video Config page. By default, PanoCams are set to 4KP30, and thus this only needs to be checked if your camera does not output 30 frames per second in full frame rate mode.

Lastly, please be aware that if you are using ONVIF to find and use the camera on AREC Media Stations or on other ONVIF-compatible devices, due to how ONVIF works, the highest resolution stream will be automatically selected. Under the default settings, this will mean that ONVIF will find the main stream, which supports ePTZ. However, if you increase the video quality of the sub-stream, ONVIF will find the substream instead.

On AREC Media Stations, there are two ways this ONVIF limitation can be bypassed:

- You can add the camera by ONVIF manually. To do that, open the "Administrator" web page of your Media Station -> "Media I/O" -> "Network Device Manager". Type the IP address of the camera, enter port 8080, username "admin", password "123456" and press "Enter". PanoCam's main stream will then be added to the list. Please note, however, that scanning for new network devices on this page will cause the station to revert back to the substream.
- All AREC Media Stations support VISCA-over-IP PTZ control, and so does the A-PC01 Pano-Cam. You can pull the camera's main stream by selecting signal type "IP Source" and the RTSP protocol and control it by VISCA-over-IP if you select it in the "PTZ Control". This is further described in the "Control Protocol Config / how to set up VISCA-over-IP controls" section of this manual.

2.1.4 Media Config / How to Set Up RTMP Streaming

PanoCam can livestream two RTMP feeds simultaneously, and you are able to choose which streams to use for that. You can configure live streaming through the “Media Config” page of the camera. It is also the page where you can change the camera’s RTSP port.

To start live streaming, first, toggle the “Enable” button to a stream you would like to customise. Next, select which stream to push: the main or the substream. Lastly, write your server URL and stream key in the field on the right. The link structure for PanoCam is the same as on AREC Media Stations:

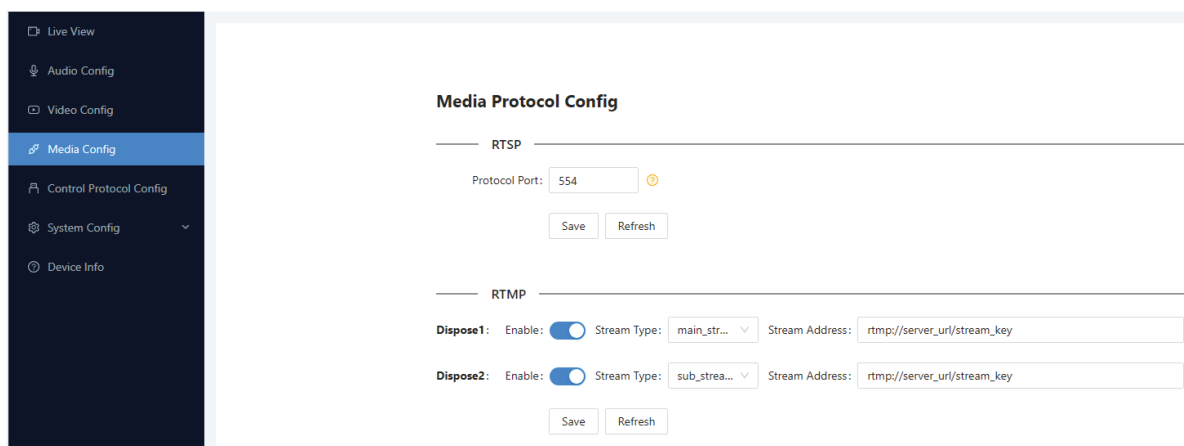

rtmp://server url/stream key

Using YouTube as an example, open YouTube.com, press “Create” -> “Go Live”.

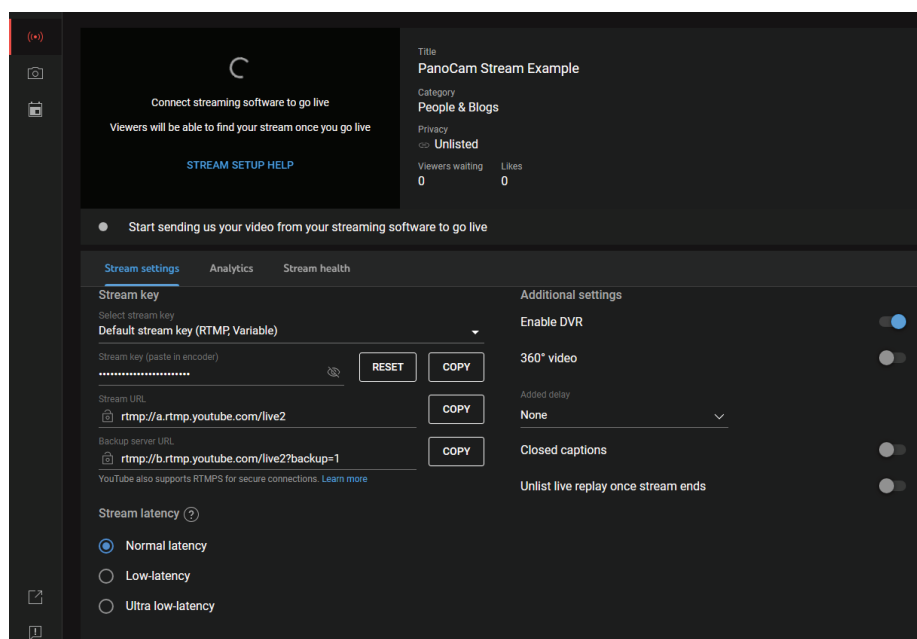

In the page that opens, first, copy the “Stream URL” and paste it in the camera’s page. Add a forward slash “/” after it. Then, copy the “Stream key” and paste it in the same field. In the end, it should look like this:

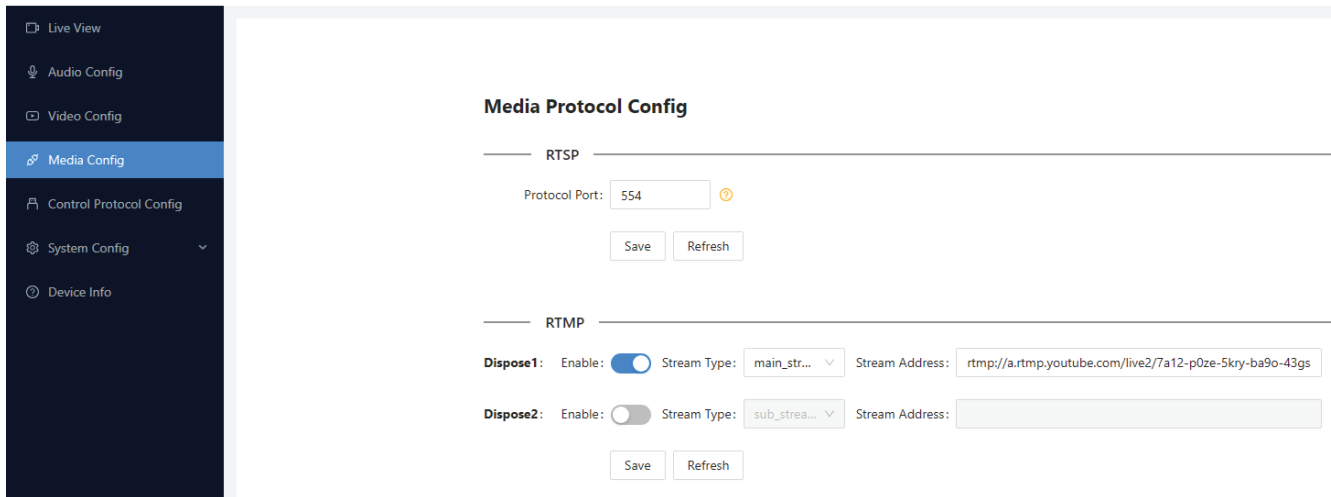

Press “Save” and “Refresh”. The camera will start streaming and you will see your live stream preview appear on YouTube shortly after.

In case YouTube or another platform does not get the live stream, please double-check that the DNS settings of your camera are configured correctly (on the “System Config” -> “Ethernet Config” page) and that the RTMP port, YouTube or other streaming service you are using are not blocked/-firewalled for the camera in your network.

2.1.5 Control Protocol Config / How to Set Up VISCA-over-IP Controls

Control Protocol Config page allows you to configure VISCA settings of your camera. By default, PanoCams are already preconfigured to be controlled by AREC Media Stations. Enable VISCA by toggling the button on this page for it to work.

Should you at some point change the settings and need to return them back, your camera should be set up as follows to be controlled by AREC devices:

Protocol: UDP

Work Mode: Server

Port: 52381

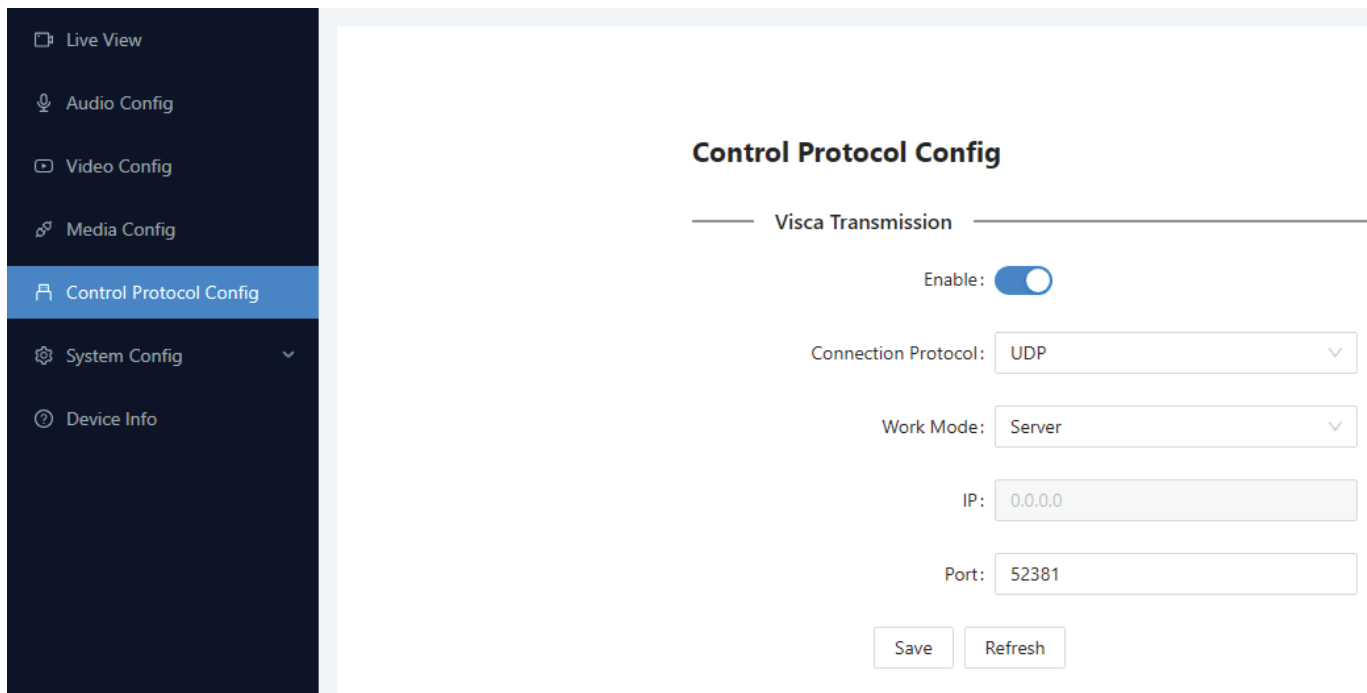

To add VISCA controls for the camera on AREC Media Stations, select the signal type “IP Source” with the RTSP protocol from the list (the default link is rtsp://ip address of the camera/ch1) and VISCA-over-IP protocol in the “PTZ Control”. Type the IP address of the camera in the “IP address” field as on the image below:

Name :
A-PC01_PanoCam

Signal type :
IP source

Protocol :
RTSP

Primary URL :
192.168.0.179/ch1

Secondary URL :
192.168.0.179/ch1

PTZ control :
VISCA over IP

IP address :
192.168.0.179

Apply

2.1.6 System Config

System config consists of three subpages:

- User Manage
- Ethernet Config
- Firmware Update

To create a new user account for the camera, click on the “User Manage” page. Click on “Add User” to do so. You can also change passwords for already created accounts by pressing the “Change Password” next to an account.

There are two types of user accounts you can create: “User” and “Operator”. The “User” account has permission to access every page, except “User Management” and “Firmware Update” pages. The “Operator” can access every page, except the “Firmware Update”. Both of these account types can be deleted at any time by the Administrator account.

Ethernet Config page allows you to set up the network settings of your camera. By default, the camera is set to a static IP address 192.168.11.200.

If you are going to connect the camera to an AREC Media Station via one of the station’s LAN ports, we recommend enabling the DHCP mode, so that the Media Station assigns the IP address to the camera itself. Nonetheless, with default settings on both AREC and RADA devices, the station will immediately see and be able to use the camera when you connect the power and network cables. You can check what is the LAN address of the station’s ports on the “Administrator” -> “System” -> “Net-work”.

The camera must be restarted after changing its network settings. You can restart it on the Firmware Update page of the camera. Press “Reboot” to restart the camera. You can also press “Reset” to return the camera to its factory default settings.

PanoCam firmware updates are provided at www.a-dena.com. To update the camera firmware, simply download the file from our website and drag it on the firmware update area or click on it to select the file and apply. The camera must restart after applying the update.

2.1.7 Device Info

Device Info page exists to show you the current firmware version of the camera and its MAC address. If you run into issues using the camera, please write down the firmware version you see on this page.